

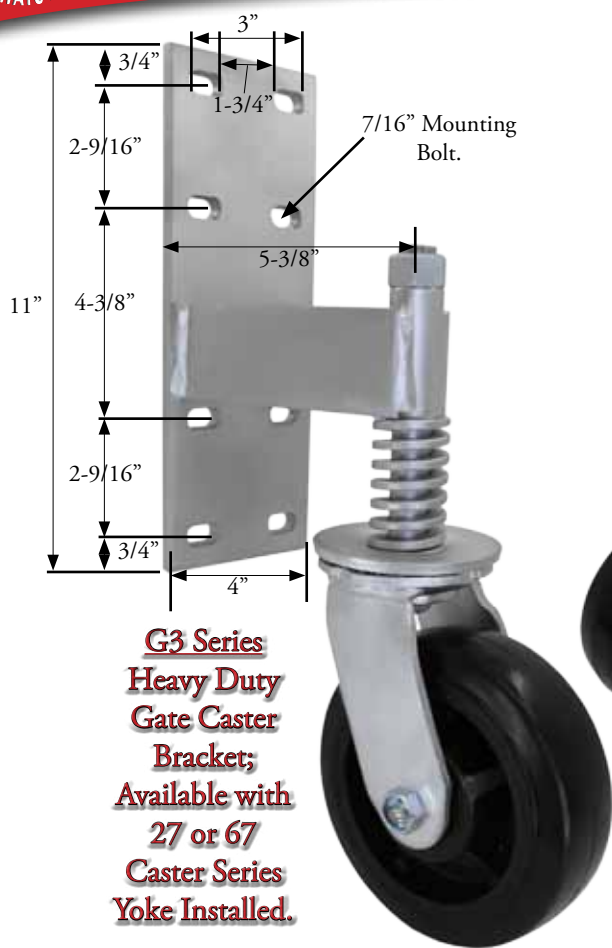

SPRING LOADED GATE CASTERS

Durable Superior Casters®



G3 Series Heavy Duty Gate Caster Bracket;
Available with 27 or 67 Caster Series Yoke Installed.

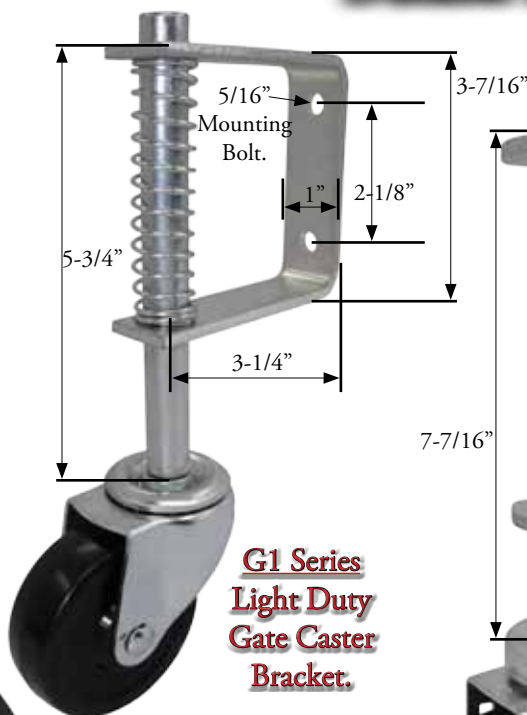

G1 Series Light Duty Gate Caster Bracket.

Any caster with appropriate fastening and swivel radius less than the "Rotating Spacing", may be inserted into the G1 & G2 series Brackets. Any 6 x 2 or 8 x 2 wheel may be used in the G3 Series Bracket.

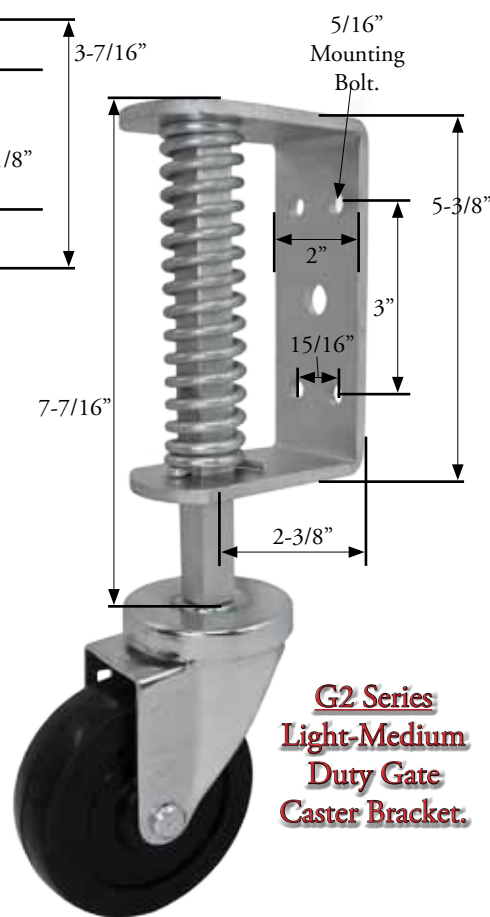

G2 Series Light-Medium Duty Gate Caster Bracket.

This series is designed specifically for use on gates and sliding or rotating doors and provides a shock absorbing ride over uneven ground; the compression spring helps support the weight of the gate/door to assist in keeping it on an even or level plain. G1 light-duty and G2 light medium duty bracket assemblies come without casters installed (*see caster requirements below*). G3 Heavy duty bracket comes with either a 6" or 8" caster yoke attached, but requires the installation of a wheel & axle to be operational.

- Any caster with the **appropriate stem fastening** may be inserted into the G1 & G2 Series Bracket as long as the casters swivel radius is less than the stated "Rotating Spacing" (***Please note:** any caster with a swivel radius larger than the "Rotating Spacing" will not be able to swivel a full 360° and will hit the gate or door the bracket assembly is attached to; and will not operate correctly).

Series	Recommended Caster Series. <i>(Make sure caster swivel radius is less than Rotating Spacing)</i>	Swivel Caster with Spring & Bracket. <i>-No wheel installed</i>	Bracket Only -No Caster Attached. Accepts 7/16" Grip Ring Stem	Bracket Only -No Caster Attached. Accepts 1/2"-13 Threaded Stem	*Rotating Spacing	Spring Deflection		Mounting Plate Specifications		
						Range (Lbs.)	Movement (Inches)	Overall Size	Bolt Size	Bolt Hole Pattern/s
G1	08 Series, 09 Series 4" & under, 21 Series 3-1/2" & under.		G1GR	G2TS	3-1/4	75 to 100	1"	1" x 3-7/16"	5/16"	2 bolts 2-1/8" apart
G2	09 Series, 21 Series.		G2GR	G2TS	2-3/8	100 to 125	1"	2" x 5-3/8"	5/16"	4 Bolts 15/16" x 3"
G2 Series recommended for use on gates with a space between the ground to bottom of the gate of 6" or more.										
G3	6" 27 Series Yoke & Bracket <i>-Requires a 6" wheel to be installed.</i> 8" 27 Series Yoke & Bracket <i>-Requires a 8" wheel to be installed.</i> 8" 67 Series Yoke & Bracket <i>-Requires a 8" wheel to be installed.</i>	G327ZZ60JZ83YY G327ZZ80JZ83YY G367ZZ80JZ83YY			5-1/4	180 to 700	1"	4" x 11"	7/16"	1-7/8" x 2-9/16" & 4-3/8" & 9-1/2"

G3 Series recommended for heavy duty gates, use 6" caster when space between ground to gate is " to 9-1/2", When space is over 9-1/2" use 8" caster

Please consult your local distributor or factory representative for help in determining the right bracket series, caster series, wheel diameter, wheel type and bearing to use. Factors to be considered are gate size, gate weight, floor condition, working environment and floor slope, etc. Custom casters are available with varying springing types, deflection ranges and capacities - please inquire.